

# potable water

expansion vessels  
vertical range



**WRAS**  
APPROVED  
PRODUCT

altecnic

# potable water expansion vessels - vertical range



## Introduction

Altecnic offer a complete range of expansion vessels to meet the requirements of most heating systems and for use with potable water.

The expansion vessels are manufactured to meet the requirements of PED 97/23/EC Directive and BS EN 13831:2007 'Closed expansion vessels with built in bladder for installation in water'.

## Design

Manufactured in carbon steel with a two or three part weld construction.

Pre-pressurised air chamber with synthetic rubber compound bladder.

Sizes 60 to 1000 litres (except 140 litres) have a replaceable bladder.

The internal surfaces of the vessel in contact with the water are coated against corrosion.

External surfaces have a blue durable powder coated finish.

Suitable for temperatures up to 70°C, resistant to ethylene glycol and propylene glycol mixtures and has low gas permeability.

Altecnic expansion vessels are all tested according to the Pressure Systems Directive.

## How It Works

In a closed hot water circuit, the water cannot be compressed so any increase in volume, created by an increase in temperature, has to be accommodated by an expansion vessel.

When water is cold, the pre-charge pressure forces the bladder to collapse until the pump is started when the bladder starts to inflate.

As the temperature in the system increases, with the associated increase in pressure and volume, the expanded water enters the bladder creating additional volume and lowering the pressure.

When the temperature decreases, the pre-charge pressure forces the water from the bladder and back into the main water circuit.

## Materials

Component	Material
Shell	Carbon steel
Connections	Carbon steel
Bladder	Synthetic rubber compound
Coating	Powder epoxy

## Technical Specification

Max. working pressure:	10 bar
Max. operating temperature:	70°C
Factory air pre-charge:	4.0 bar - nitrogen
Replaceable bladder - sizes:	50 litres and larger except 140 litres size
System water connection thread:	BE EN ISO 228 - female
140 litre size:	BE EN 10226 - male

## E & O.E

Altecnic Ltd Mustang Drive, Stafford, Staffordshire ST16 1GW

T: +44 (0)1785 218200 E: sales@altecnic.co.uk

Registered in England No: 2095101

altecnic.co.uk

AL 104 19-09-12

## Dimensions

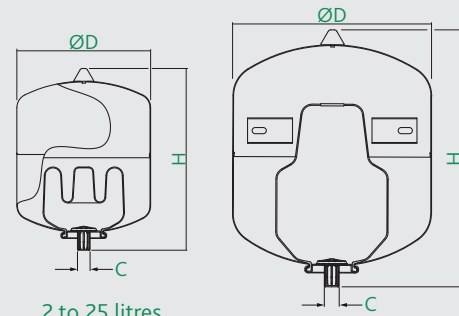

2 to 25 litres

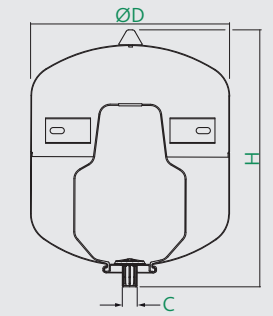

33 litres - with wall bracket

Product Code	Capacity	ØD	H	C	Weight
	litres	mm	mm	Connection	kg
PV8W	8	206	325	G $\frac{3}{4}$	1.8
PV12W	12	280	310	G $\frac{3}{4}$	2.4
PV18W	18	280	380	G $\frac{3}{4}$	2.8
PV25W	25	280	500	G $\frac{3}{4}$	4.7
PV33W	33	354	455	G $\frac{3}{4}$	6.6

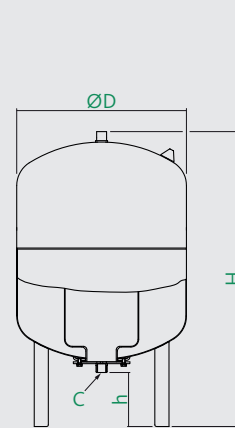

50 to 500 litres

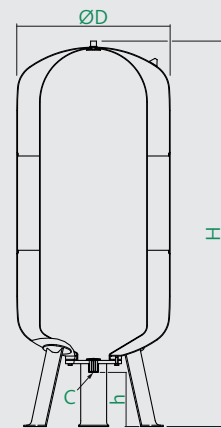

600 and 1000 litres

Product Code	Capacity	ØD	H	h	C	Weight
	litres	mm	mm	mm	Connection	kg
PV50W	50	409	605	104	G1	9.5
PV60W	60	409	740	152	G1	14
PV80W	80	480	730	152	G1	16
PV100W	100	480	835	152	G1	19
PV140W	140	480	1015	145	R1	29
PV200W	200	634	970	145	G1 $\frac{1}{4}$	40
PV300W	300	634	1270	145	G1 $\frac{1}{4}$	54
PV400W	400	740	1245	135	G1 $\frac{1}{4}$	70
PV500W	500	740	1475	135	G1 $\frac{1}{4}$	79
PV600W	600	740	1860	265	G1 $\frac{1}{2}$	103
PV800W	800	740	2325	265	G1 $\frac{1}{2}$	195
PV1000W	1000	740	2604	265	G1 $\frac{1}{2}$	228

CE marked  
WRAS approved product